

PILCO



ESTD. 1890

ABDULHUSEIN PEERBHOY & SONS

A PEERBHOY BLDG • 66-68 NARAYAN RAO KOLI MARG (BHANDARI ST.) • MUMBAI 400 003 • INDIA
TEL: 3423956, 3420014 • FACSIMILE: +91+22+3415133 • EMAIL: apeerbhoy@hotmail.com



LASHING CHAINS



LIFTING CHAINS



ANCHOR CHAINS

CHAINS & CHAIN SLINGS

WORKING LOAD LIMIT (SWL):

The Working Load Limit is the maximum load which should ever be applied to a chain, when the load is uniformly applied in direct tension to a straight length of chain.

MINIMUM ULTIMATE LOAD (BL):

The Minimum Ultimate Load is the minimum load at which a chain will break when tested by applying direct tension to a straight length of chain at a uniform rate of speed in a testing machine.

PROOF TEST (PL):

Proof Test is a term designating the tensile test applied to a chain for the sole purpose of detecting injurious defects in the material or manufacture. It is a load which has withstood under a test in direct tension to a straight length of chain.

ATTACHMENTS:

Any attachments such as hooks or links should have a rated working load limit at least equal to the chain with which it is used.

TO ORDER YOUR CHAIN SLINGS:

Determine the maximum load to be lifted by the sling assembly, i.e. SWL (Safe Working Load). Choose the type of sling suited for the shape of the load, and the size of the sling for the load to be lifted. The decision must take into account the angle (i.e. 0° to 90°) of the sling legs in multileg slings. We can help you select components and end attachments for your specific needs.

Chains & Slings as per LS.2760/1984







All our products comply with ISI specifications and some are also ISO9000 approved.

We can also offer from ex-stock STAINLESS STEEL & BRASS CHAINS.

Certification from our own Rigging and Gears Test Certificate or a Certificate from a Government Approved Test House can be furnished.

ABDULHUSEIN PEERBHOY & SONS

A PEERBHOY BLDG • 66-68 NARAYAN RAO KOLI MARG (BIHANDARI ST.) • MUMBAI 400 003 • INDIA
 TEL: 3423956, 3420014 • FACSIMILE: +91+22+3415133 • EMAIL: apeerbhoy@hotmail.com

TABLE 1			SINGLE LEG	ENDLESS SLING	WORKING LOAD LIMIT IN TONNES*			
NOMINAL SIZE OF CHAIN IN MM.					MULTIPLE LEG SLINGS			
GRADE 30	GRADE 63	GRADE 80						
12	9	8	2	2	2.8	4.2	4.2	2.8
14	10	9	2.5	2.5	3.5	5.2	5.2	3.5
16	12	10	3.2	3.2	4.5	6.7	6.7	4.5
20	14	12	5	5	7	10.5	10.5	7
22	16	14	6.3	6.3	8.8	13.2	13.2	8.8
25	18	16	8	8	11.2	16.8	16.8	11.2
28	20	18	10	10	14	21.0	21.0	14
32	22	20	12.5	12	17.5	26.2	26.2	17.5
36	25	22	16	16	22.4	33.6	33.6	22.4
40	28	25	20	20	28	42.0	42.0	28
45	32	28	25	25	35	52.5	52.5	35
-	36	32	32	32	44.8	67.2	67.2	44.8
-	40	-	40	40	56	84	84	56
-	45	-	50	50	70	105	105	70

CHAINS OF VARIOUS GRADES				
TABLE 2				
CHAIN SIZE IN MM	SAFE WORKING LOAD IN TONNES			
	GRADE 30	GRADE 40	GRADE 63	GRADE 80
8	.8	1	1.6	2.0
10	1.25	1.6	2.5	3.2
12.5	2.0	2.5	4	5.0
16	3.2	4.0	6.3	8.0
20	5.0	6.3	10	12.5
22	6.3	8.0	12.5	16
25	8	10	16	20
28	10	12.5	20	25
32	12.5	16	25	32

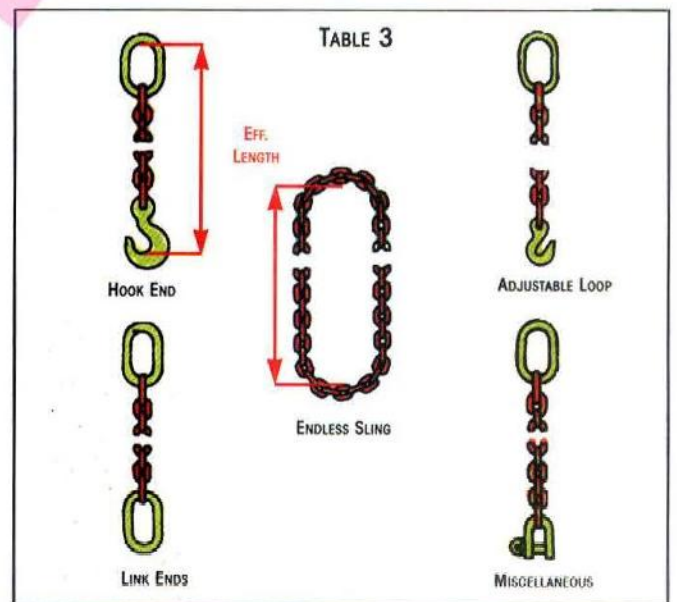

Size: While choosing sizes of the chains, top angle between the legs of the sling should be considered. The safe working load of the sling reduces as this angle increases. If in doubt, call for detailed information on the safe working load of various slings at different angles. Refer to Table 1. *SWL at an included angle of 90°.

Grade of Chains: Choose the right chain for your purpose from the table shown above, showing the safe working load limits for various grades of chains. Refer to Table 2.

Type: Specify the type of sling required. If any special assembly is desired, provide a drawing or detailed description. Refer to Table 3.

Attachments: In the normal course we will use the standard recommended dimensions of attachments. However, if you require any specific dimensions to be used please select the suitable link, ring, or hook. Refer to Table 3.

Effective Length: Specify the desired length from upper bearing surface of top attachment to lower bearing surface of bottom attachment.

Steel Stud Link Chain & Fitting



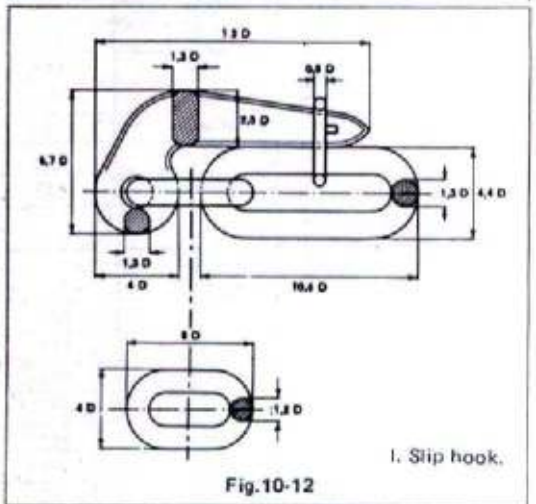
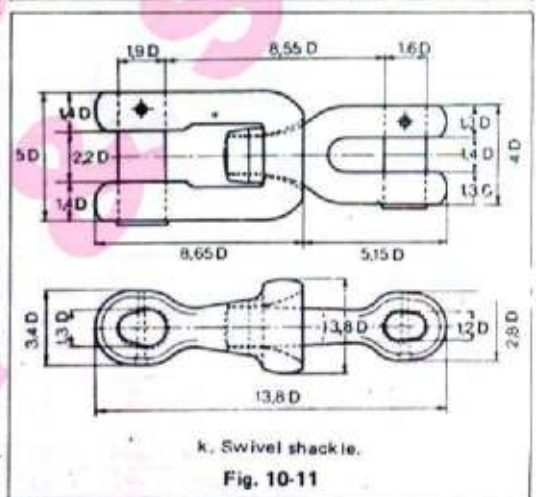
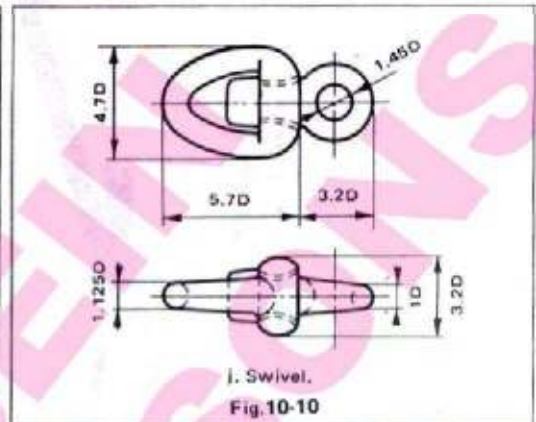
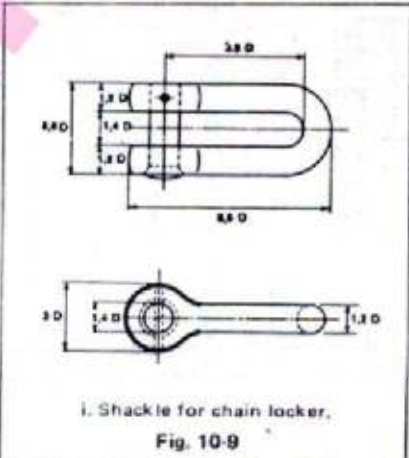
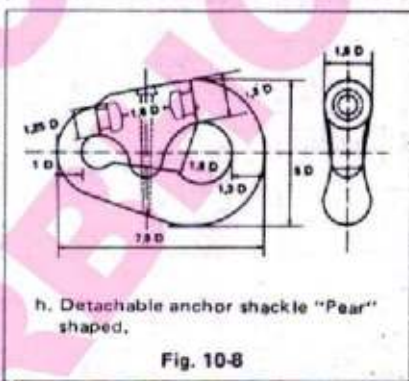
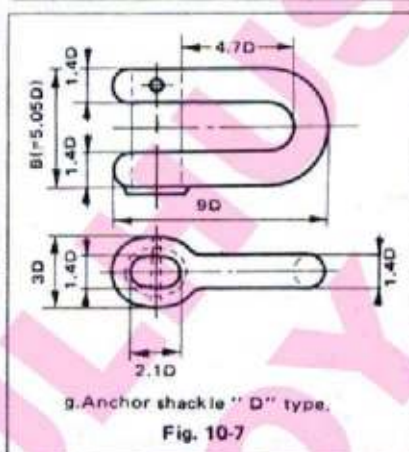
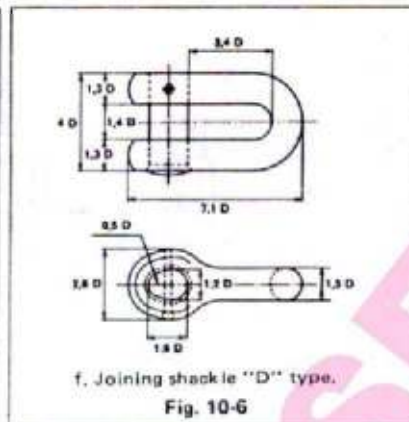
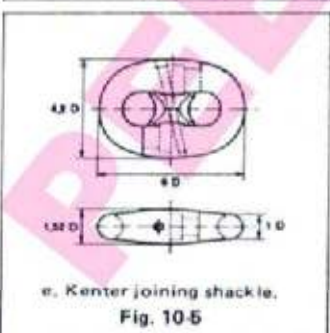
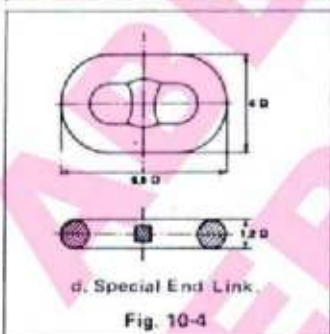
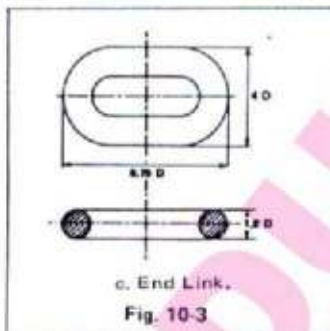
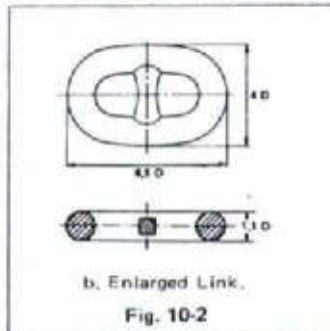
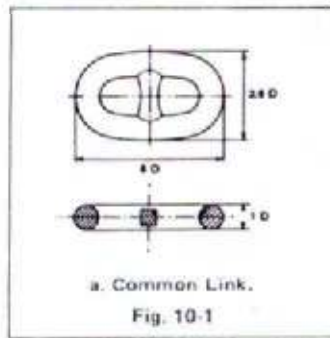





Stud Link Chain Cable & Fittings For Ships

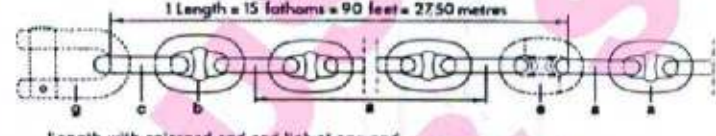
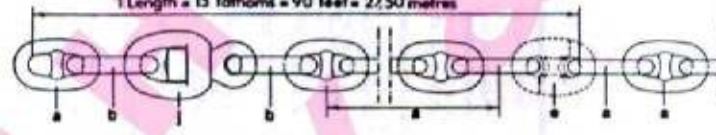
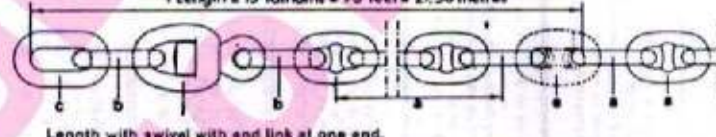
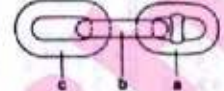

D = Nominal diameter of chain.

Steel Stud Link Chain & Fitting

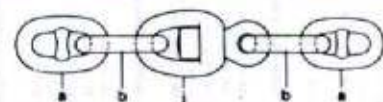
Standard Arrangements For Ships.

L-1	 <p>1 Length = 15 fathoms = 90 feet = 2750 metres</p> <p>Length with normal links only. Connection by kenter joining shackle.</p>
L-2	 <p>1 Length = 15 fathoms = 90 feet = 2750 metres</p> <p>Length with enlarged and end links at both ends. Connection by joining shackle "D" type.</p>
L-3	 <p>1 Length = 15 fathoms = 90 feet = 2750 metres</p> <p>Length with enlarged and end link at one end.</p>
L-4	 <p>1 Length = 15 fathoms = 90 feet = 2750 metres</p> <p>Length with swivel with normal links at both ends.</p>
L-5	 <p>1 Length = 15 fathoms = 90 feet = 2750 metres</p> <p>Length with swivel with end link at one end.</p>
E-1	 <p>Normal adaptor piece.</p>
E-2	 <p>Special adaptor piece.</p>
F-1	 <p>Swivel with 4 links (forerunner).</p>
F-2	 <p>Swivel with 4 links (forerunner).</p>
F-3	 <p>Swivel with 4 links (forerunner).</p>
F-4	 <p>Swivel with 3 links (forerunner).</p>

Steel Stud Link Chain & Fitting

Common Links(C/L)

$$D = d + \text{Tolerance}$$

$$L = 6d \begin{matrix} +0.15d \\ -0 \end{matrix}$$

$$W = 3.6d \begin{matrix} +0.10d \\ -0 \end{matrix}$$

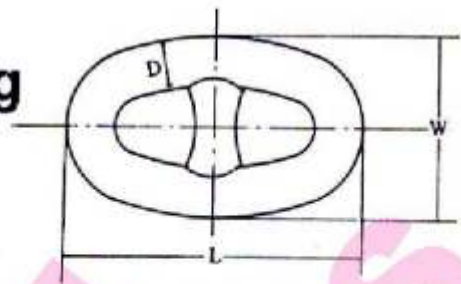

Nominal Dia.d	Diameter D			Length L		Width W		
	Min.	Standard	Max.	Standard	Max.	Min.	Standard	Max.
mm	mm	mm	mm	mm	mm	mm	mm	mm
16	15.5	16.0	17.5	96.0	98.4	56.0	57.6	59.2
17.5	17.0	17.5	19.0	105.0	107.6	61.3	63.0	64.8
19	18.5	19.0	20.5	114.0	116.9	66.5	68.4	70.3
20.5	20.0	20.5	22.0	123.0	126.1	71.8	73.8	75.9
22	21.5	22.0	23.5	132.0	135.3	77.0	79.2	81.4
24	23.5	24.0	25.5	144.0	147.6	84.0	86.4	88.8
26	25.5	26.0	27.5	156.0	159.9	91.0	93.6	96.2
28	27.5	28.0	29.5	168.0	172.2	98.0	100.8	103.2
30	29.5	30.0	32.0	180.0	184.5	105.0	108.0	111.0
32	31.5	32.0	34.0	192.0	196.8	112.0	115.2	118.4
34	33.5	34.0	36.0	204.0	209.1	119.0	122.4	125.8
36	35.5	36.0	38.0	216.0	221.4	126.0	129.6	133.2
38	37.5	38.0	40.0	228.0	233.7	133.0	136.8	140.6
40	39.5	40.0	42.0	240.0	246.0	140.0	144.0	148.0
42	41.5	42.0	44.0	252.0	258.3	147.0	151.2	155.4
44	43.5	44.0	46.0	264.0	270.6	154.0	158.4	162.8
46	45.5	46.0	48.0	276.0	282.9	161.0	165.6	170.2
48	47.5	48.0	50.0	288.0	295.2	168.0	172.8	177.6
50	49.5	50.0	52.0	300.0	307.5	175.0	180.0	185.0
52	51.0	52.0	54.0	312.0	319.8	182.0	187.2	192.4
54	53.0	54.0	56.5	324.0	332.1	189.0	194.4	199.8
56	55.0	56.0	58.5	336.0	344.4	196.0	201.6	207.2
58	57.0	58.0	60.5	348.0	356.7	203.0	208.8	214.6
60	59.0	60.0	62.5	360.0	369.0	210.0	216.0	222.0
62	61.0	62.0	64.5	372.0	381.3	217.0	223.2	229.4
64	63.0	64.0	66.5	384.0	393.6	224.0	230.4	236.8
66	65.0	66.0	68.5	396.0	405.9	231.0	237.6	244.2
68	67.0	68.0	70.5	408.0	418.2	238.0	244.8	251.6
70	69.0	70.0	72.5	420.0	430.5	245.0	252.0	259.0
73	72.0	73.0	76.0	438.0	449.0	255.5	262.8	270.1
76	75.0	76.0	79.0	456.0	467.4	266.0	273.6	281.2
78	77.0	78.0	81.0	468.0	479.7	273.0	280.8	288.6
81	80.0	81.0	84.0	486.0	498.2	283.5	291.6	299.7
84	83.0	84.0	87.0	504.0	516.6	294.0	302.4	310.8
87	86.0	87.0	90.0	522.0	535.1	304.5	313.2	321.9
90	89.0	90.0	93.5	540.0	553.5	315.0	324.0	333.0
92	91.0	92.0	95.5	552.0	565.8	322.0	331.2	340.4
95	94.0	95.0	98.5	570.0	584.3	332.0	342.0	351.5
97	96.0	97.0	100.5	582.0	596.6	339.5	349.2	358.9
98	97.0	98.0	101.5	588.0	602.7	343.0	352.8	362.6
100	99.0	100.0	103.5	600.0	615.0	350.0	360.0	370.0
102	101.0	102.0	106.0	612.0	627.3	357.0	367.2	377.4
105	104.0	105.0	109.0	630.0	645.8	367.5	378.0	388.5
107	106.0	107.0	111.0	642.0	658.1	374.5	385.5	395.9
108	107.0	108.0	112.0	648.0	664.2	378.0	388.8	399.6
114	110.0	111.0	115.0	666.0	682.7	388.5	399.6	410.7
114	113.0	114.0	118.0	684.0	701.1	399.0	410.4	421.8
117	116.0	117.0	121.0	702.0	719.6	409.5	421.2	432.9
120	119.0	120.0	124.0	720.0	738.0	420.0	432.0	444.0
122	121.0	122.0	127.0	732.0	750.3	427.0	439.2	451.4
124	123.0	124.0	129.0	744.0	762.6	434.0	446.4	458.8
127	126.0	127.0	132.0	762.0	781.1	444.5	457.2	469.9
130	129.0	130.0	135.0	780.0	799.5	455.0	468.0	481.0
132	131.0	132.0	137.0	792.0	811.8	462.0	475.2	488.4
137	136.0	137.0	142.0	822.0	842.6	479.5	493.2	506.9
142	141.0	142.0	147.0	852.0	873.3	497.0	511.2	525.4
147	146.0	147.0	152.0	882.0	904.1	514.5	529.2	543.9
152	151.0	152.0	157.0	912.0	934.8	532.0	547.2	562.4

Steel Stud Link Chain & Fitting

Enlarge Links (EL/L)

$$D = 1.1d + \text{Tolerance}$$

$$L = 6.5d \begin{matrix} +0.15d \\ -0 \end{matrix}$$

$$W = 4d \begin{matrix} +0.1d \\ -0 \end{matrix}$$

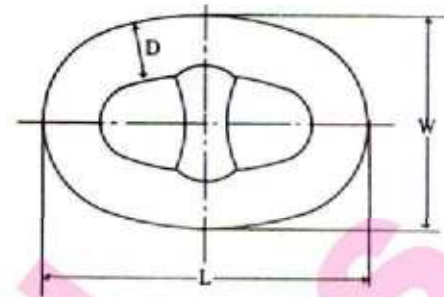

Nominal Dia. d	Diameter D			Length L		Width W		
	Min.	Standard	Max.	Standard	Max.	Min.	Standard	Max.
mm	mm	mm	mm	mm	mm	mm	mm	mm
16	17.1	17.6	19.1	104.0	106.4	62.4	64.0	65.6
17.5	18.8	19.3	20.8	113.8	116.4	68.3	70.0	71.8
19	20.4	20.9	22.4	123.5	126.4	74.1	76.0	77.9
20.5	22.1	22.6	24.1	133.3	136.3	80.0	82.0	84.1
22	23.7	24.2	25.7	143.0	146.3	85.8	88.0	90.2
24	25.9	26.4	27.9	155.0	159.6	93.6	96.0	98.7
26	28.1	28.6	30.1	169.0	172.9	101.4	104.0	106.6
28	30.3	30.8	32.3	182.0	186.2	109.2	112.0	114.8
30	32.5	33.0	35.0	195.0	199.5	117.0	120.0	123.0
32	34.7	35.2	37.2	208.0	212.8	124.8	128.0	131.2
34	36.9	37.4	39.4	221.0	226.1	132.6	136.0	139.4
36	39.1	39.6	41.6	234.0	239.4	140.4	144.0	147.6
38	41.3	41.8	43.8	247.0	252.7	148.2	152.0	155.8
40	43.5	44.0	46.0	260.0	266.0	156.0	160.0	164.0
42	45.7	46.2	48.2	273.0	279.3	163.8	168.0	172.2
44	47.9	48.4	50.4	286.0	292.6	171.6	176.0	180.4
46	50.1	50.6	52.6	299.0	305.9	179.6	184.0	188.6
48	52.3	52.8	54.8	312.0	319.2	187.2	192.0	196.8
50	54.5	55.0	57.0	325.0	332.5	195.0	200.0	205.0
52	56.7	57.2	59.7	338.0	345.8	202.8	208.0	213.2
54	58.9	59.4	61.9	351.0	359.1	210.6	216.0	221.4
56	60.6	61.6	64.1	364.0	372.4	218.4	224.0	229.6
58	62.8	63.8	66.3	377.0	385.7	226.2	232.0	237.8
60	65.0	66.0	68.5	390.0	399.0	234.0	240.0	246.0
62	67.2	68.2	70.7	403.0	412.3	241.8	248.0	254.2
64	69.4	70.4	72.9	416.0	425.6	249.6	256.0	262.4
66	71.6	72.6	75.1	429.0	438.9	257.4	264.0	270.6
68	73.8	74.8	77.3	442.0	452.2	265.2	272.0	278.8
70	76.0	77.0	79.5	455.0	465.5	273.0	280.0	287.0
73	79.3	80.3	83.3	474.5	485.5	284.7	292.0	299.3
76	82.6	83.6	86.6	494.0	505.4	296.4	304.0	311.6
78	84.8	85.8	88.8	507.0	518.7	304.2	312.0	319.8
81	88.1	89.1	92.1	526.5	538.7	315.9	324.0	332.1
84	91.4	92.4	95.4	546.0	558.6	327.6	336.0	344.4
87	94.7	95.7	98.7	565.5	578.6	339.3	348.0	356.7
90	98.0	99.0	102.5	585.0	598.5	351.0	360.0	369.0
92	100.2	101.2	104.7	598.0	611.8	358.8	368.0	377.2
95	103.5	104.5	108.0	617.5	631.8	370.5	380.0	389.5
97	105.7	106.7	110.2	630.0	645.1	378.3	388.0	397.7
98	106.8	107.8	111.3	637.0	651.7	382.2	392.0	401.8
100	109.0	110.0	113.5	650.0	665.0	390.0	400.0	410.0
102	111.2	112.2	116.2	663.0	678.3	397.8	408.0	418.2
105	114.5	115.5	119.5	682.5	698.3	409.5	420.0	430.5
107	116.7	117.7	121.7	695.5	711.6	417.3	428.0	438.7
108	117.8	118.8	122.8	702.0	718.2	421.2	432.0	442.8
111	121.1	122.1	126.1	721.5	738.2	432.9	444.0	455.1
114	124.4	125.4	129.4	741.0	758.1	444.6	456.0	467.4
117	127.7	128.7	132.7	760.5	778.1	456.3	468.0	479.7
120	131.0	132.0	136.0	780.0	798.0	468.0	480.0	492.0
122	133.2	134.2	139.2	793.0	811.3	475.8	488.0	500.2
124	135.4	136.4	141.4	806.0	824.6	483.6	496.0	508.4
127	138.7	139.7	144.7	825.5	844.6	495.3	508.0	520.7
130	142.0	143.0	148.0	845.0	864.5	507.0	520.0	533.0
132	144.2	145.2	150.2	858.0	877.8	514.8	528.0	541.2
137	149.7	150.7	155.7	890.5	911.1	534.3	548.0	561.7
142	155.2	156.2	161.2	923.0	944.3	553.8	568.0	582.2
147	160.7	161.7	166.7	955.5	977.6	573.3	588.0	602.7
152	166.2	167.2	172.2	988.0	1010.8	592.8	608.0	623.2

Steel Stud Link Chain & Fitting

End Links (E/L)

$$D = 1.2d + \text{Tolerance}$$

$$L = 6.75d \begin{matrix} +0.15d \\ -0 \end{matrix}$$

$$W = 4D \begin{matrix} +0.15d \\ -0 \end{matrix}$$

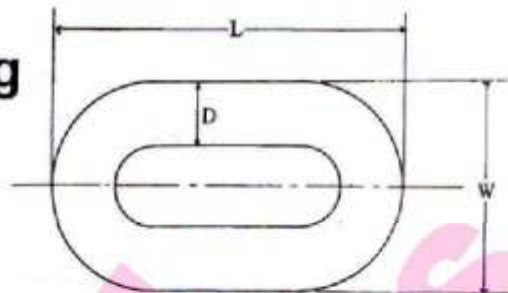

Nominal Dia. d	Diameter D			Length L		Width W	
	Min.	Standard	Max.	Standard	Max.	Standard	Max.
mm	mm	mm	mm	mm	mm	mm	mm
16	18.7	19.2	20.7	108.0	110.4	64.0	66.4
17.5	20.5	21.0	22.5	118.1	120.8	70.0	72.6
19	22.3	22.8	24.3	128.3	131.1	76.0	78.9
20.5	24.1	24.6	26.1	138.4	141.5	82.0	85.1
22	25.9	26.4	27.9	148.5	151.8	88.0	91.3
24	28.3	28.8	30.3	162.0	165.6	96.0	99.6
26	30.7	31.2	32.7	175.5	179.4	104.0	107.9
28	33.1	33.6	35.1	189.0	193.2	112.0	116.2
30	35.5	36.0	38.0	202.5	207.0	120.0	124.5
32	37.9	38.4	40.4	216.0	220.8	128.0	132.8
34	40.3	40.8	42.8	229.5	234.6	136.0	141.1
36	42.7	43.2	45.2	243.0	248.4	144.0	149.4
38	45.1	45.6	47.6	256.5	262.2	152.0	157.7
40	47.5	48.0	50.0	270.0	276.0	160.0	166.0
42	49.9	50.4	52.4	283.5	289.8	168.0	174.3
44	52.3	52.8	54.8	297.0	303.6	176.0	182.6
46	54.7	55.2	57.2	310.5	317.4	184.0	190.9
48	57.1	57.6	59.6	324.0	331.2	192.0	199.2
50	59.5	60.0	62.0	337.5	345.0	200.0	207.5
52	61.9	62.4	64.9	351.0	358.8	208.0	215.8
54	64.3	64.8	67.3	364.5	372.6	216.0	224.1
56	66.7	67.2	69.7	378.0	386.4	224.0	232.4
58	69.1	69.6	72.1	391.5	400.2	232.0	240.7
60	71.5	72.0	74.5	405.0	414.0	240.0	249.0
62	73.9	74.4	76.9	418.5	427.8	248.0	257.3
64	76.3	76.8	79.3	432.0	441.6	256.0	265.6
66	78.7	79.2	81.7	445.5	455.4	264.0	273.9
68	81.1	81.6	84.1	459.0	469.2	272.0	282.2
70	83.5	84.0	86.5	472.5	483.0	280.0	290.5
73	86.6	87.6	90.6	492.8	503.7	292.0	303.0
76	90.2	91.2	94.2	513.0	524.4	304.0	315.4
78	92.6	93.6	96.6	526.5	538.2	312.0	323.7
81	96.2	97.2	100.2	546.8	558.9	324.0	336.2
84	99.8	100.8	103.8	567.0	579.6	336.0	348.6
87	103.4	104.4	107.4	587.3	600.3	348.0	361.1
90	107.0	108.0	111.5	607.5	621.0	360.0	373.5
92	109.4	110.4	113.9	621.0	634.8	368.0	381.8
95	113.0	114.0	117.5	641.3	655.5	380.0	394.3
97	115.4	116.4	119.9	654.8	669.3	388.0	402.6
98	116.6	117.6	121.1	661.5	676.2	392.0	406.7
100	119.0	120.0	123.5	675.0	690.0	400.0	415.0
102	121.4	122.4	126.4	688.5	703.8	408.0	423.3
105	125.0	126.0	130.0	708.8	724.5	420.0	435.8
107	127.4	128.4	132.4	722.3	738.3	428.0	444.1
108	128.6	129.6	133.6	729.0	745.2	432.0	448.2
114	132.2	133.2	137.2	749.3	765.9	444.0	460.7
114	135.8	136.8	140.8	769.5	786.6	456.0	473.1
117	139.4	140.4	144.4	789.8	807.3	468.0	485.6
120	143.0	144.0	148.0	810.0	828.0	480.0	498.0
122	145.4	146.4	151.4	823.5	841.8	488.0	506.3
124	147.8	148.8	153.8	837.0	855.6	496.0	514.6
127	151.4	152.4	157.4	857.3	876.3	508.0	527.1
130	155.0	156.0	161.0	877.5	897.0	520.0	539.5
132	157.4	158.4	163.4	891.0	910.8	528.0	547.8
137	163.4	164.4	169.4	924.8	945.3	548.0	568.6
142	169.4	170.4	175.4	958.5	979.8	568.0	589.3
147	175.4	176.4	181.4	992.3	1014.3	588.0	610.1
152	181.4	182.4	187.4	1026.0	1048.8	608.0	630.8

Steel Stud Link Chain & Fitting

Kenter Shackles (K/S)

$$D = d + \text{Tolerance}$$

$$L = 6d \begin{matrix} +0.15d \\ -0 \end{matrix}$$

$$W = 4.2d \begin{matrix} +0.10d \\ -0.10d \end{matrix}$$

$$B = 1.52d$$

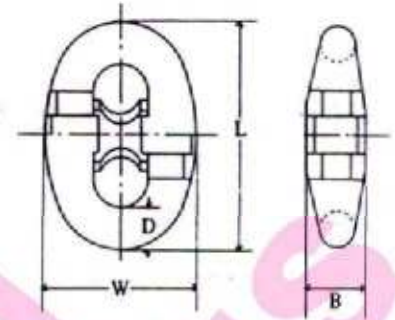

Nominal Dia.d	Diameter D			Length L		Width W			B
	Min.	Standard	Max.	Standard	Max.	Min.	Standard	Max.	
mm	mm	mm	mm	mm	mm	mm	mm	mm	mm
16	15.5	16.0	17.5	96	98.4	65.6	67.2	68.8	24.3
17.5	17.0	17.5	19.0	105	107.6	71.8	73.5	75.3	26.6
19	18.5	19.0	20.5	114	116.9	77.9	79.8	81.7	28.9
20.5	20.0	20.5	22.0	123	126.1	84.1	86.1	88.2	31.2
22	21.5	22.0	23.5	132	135.3	90.2	92.4	94.6	33.4
24	23.5	24.0	25.5	144	147.6	98.4	100.8	103.2	36.5
26	25.5	26.0	27.5	156	159.9	106.6	109.2	111.8	39.5
28	27.5	28.0	29.5	168	172.2	114.8	117.6	120.4	42.6
30	29.5	30.0	32.0	180	184.5	123.0	126.0	129.0	45.6
32	31.5	32.0	34.0	192	196.8	131.2	134.4	137.6	48.6
34	33.5	34.0	36.0	204	209.1	139.4	142.8	146.2	51.7
36	35.5	36.0	38.0	216	221.4	147.6	151.2	154.8	54.7
38	37.5	38.0	40.0	228	233.7	155.8	159.6	163.4	57.8
40	39.5	40.0	42.0	240	246.0	164.0	168.0	172.0	60.8
42	41.5	42.0	44.0	252	258.3	172.2	176.4	180.6	63.8
44	43.5	44.0	46.0	264	270.6	180.4	184.8	189.2	66.9
46	45.5	46.0	48.0	276	282.9	188.6	193.2	197.8	69.9
48	47.5	48.0	50.0	288	295.2	196.8	201.6	206.4	73.0
50	49.5	50.0	52.0	300	307.5	205.0	210.0	215.0	76.0
52	51.0	52.0	54.5	312	319.8	213.2	218.4	223.6	79.0
54	53.0	54.0	56.5	324	332.1	221.4	226.8	232.2	82.1
56	55.0	56.0	58.5	336	344.4	229.6	235.2	240.8	85.1
58	57.0	58.0	60.5	348	356.7	237.8	243.6	249.4	88.2
60	59.0	60.0	62.5	360	369.0	246.0	252.0	258.0	91.2
62	61.0	62.0	64.5	372	381.3	254.2	260.4	266.6	94.2
64	63.0	64.0	66.5	384	393.6	262.4	268.8	275.2	97.3
66	65.0	66.0	68.5	396	405.9	270.6	277.2	283.8	100.3
68	67.0	68.0	70.5	408	418.2	278.8	285.6	292.4	103.4
70	69.0	70.0	72.5	420	430.5	287.0	294.0	301.0	106.4
73	72.0	73.0	76.0	438	449.0	299.3	306.6	313.9	111.0
76	75.0	76.0	79.0	456	467.4	311.6	319.2	326.8	115.5
78	77.0	78.0	81.0	468	479.7	319.8	327.6	335.4	118.6
81	80.0	81.0	84.0	486	498.2	332.1	340.2	348.3	123.1
84	83.0	84.0	87.0	504	516.6	344.4	352.8	361.2	127.7
87	86.0	87.0	90.0	522	535.1	356.7	365.4	374.1	132.2
90	89.0	90.0	93.5	540	553.5	369.0	378.0	387.0	136.8
92	91.0	92.0	95.5	552	565.8	377.2	386.4	395.6	139.8
95	94.0	95.0	98.5	570	584.3	389.5	399.0	408.5	144.4
97	96.0	97.0	100.5	582	596.6	397.7	407.4	417.1	147.4
98	97.0	98.0	101.5	588	602.7	401.8	411.6	421.4	149.0
100	99.0	100.0	103.5	600	615.0	410.0	420.0	430.0	152.0
102	101.0	102.0	106.0	612	627.3	418.2	428.4	438.6	155.0
105	104.0	105.0	109.0	630	645.8	430.5	441.0	451.5	159.6
107	106.0	107.0	111.0	642	658.1	438.7	449.4	460.1	162.6
108	107.0	108.0	112.0	648	664.2	442.8	453.6	464.4	164.2
111	110.0	111.0	115.0	666	682.7	455.1	466.2	477.3	168.7
114	113.0	114.0	118.0	684	701.1	467.4	478.8	490.2	173.3
117	116.0	117.0	121.0	702	719.6	479.7	491.4	503.1	177.8
120	119.0	120.0	124.0	720	738.0	492.0	504.0	516.0	182.4
122	121.0	122.0	127.0	732	750.3	500.2	512.4	524.6	185.4
124	123.0	124.0	129.0	744	762.6	508.4	520.8	533.2	188.5
127	126.0	127.0	132.0	762	781.1	520.7	533.4	546.1	193.0
130	129.0	130.0	135.0	780	799.5	533.0	546.0	559.0	197.6
132	131.0	132.0	137.0	792	811.8	541.2	554.4	567.6	200.6
137	136.0	137.0	142.0	822	842.6	561.7	575.4	589.1	208.2
142	141.0	142.0	147.0	852	873.3	582.2	596.4	610.6	215.8
147	146.0	147.0	152.0	882	904.1	602.7	617.4	632.1	223.4
152	151.0	152.0	157.0	912	934.8	623.2	638.4	653.6	231.0

Steel Stud Link Chain & Fitting

Joining Shackles (J/S)

$$D = 1.3d + \text{Tolerance}$$

$$L = 7.1d + \frac{0.15d}{0}$$

$$W = 4d + \frac{0.15d}{0}$$

$$R = 0.8d$$

$$N = 2.8d$$

$$S = 1.6d$$

$$U = 1.2d$$

$$T = 1.0d$$

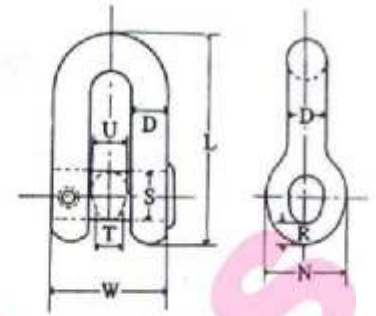

Nominal Dia. d	Diameter D			Length L		Width W		R	N	S	U	T
	Min.	Standard	Max.	Standard	Max.	Standard	Max.					
mm	mm	mm	mm	mm	mm	mm	mm	mm	mm	mm	mm	mm
16	20.3	20.8	22.3	113.6	116.0	64	66.4	12.8	44.3	25.6	19.2	16.0
17.5	22.3	22.8	24.3	124.3	126.9	70	72.6	14.0	49.0	28.0	21.0	17.5
19	24.2	24.7	26.2	134.9	137.8	76	78.9	15.2	53.2	30.4	22.8	19.0
20.5	26.2	26.7	28.2	145.6	148.6	82	85.1	16.4	57.4	32.8	24.6	20.5
22	28.1	28.6	30.1	156.2	159.5	88	91.3	17.6	61.6	35.2	26.4	22
24	30.7	31.2	32.7	170.4	174.0	96	99.6	19.2	67.2	38.4	28.8	24
26	33.3	33.8	35.3	184.6	188.5	104	107.9	20.8	72.8	41.6	31.2	26
28	35.9	36.4	37.9	198.8	203.0	112	116.2	22.4	78.4	44.8	33.6	28
30	38.5	39.0	41.0	213.0	217.5	120	124.5	24.0	84.0	48.0	36.0	30
32	41.1	41.6	43.6	227.2	232.0	128	132.8	25.6	89.6	51.2	38.4	32
34	43.7	44.2	46.2	241.4	246.5	136	141.1	27.2	95.2	54.4	40.8	34
36	46.3	46.8	48.8	255.6	261.0	144	149.4	28.8	100.8	57.6	43.2	36
38	48.9	49.4	51.4	269.8	275.5	152	157.7	30.4	106.4	60.8	45.6	38
40	51.5	52.0	54.0	284.0	290.0	160	166.0	32.0	112.0	64.0	48.0	40
42	54.1	54.6	56.6	298.2	304.5	168	174.3	33.6	117.6	67.2	50.4	42
44	56.7	57.2	59.2	312.4	319.0	176	182.6	35.2	123.2	70.4	52.8	44
46	59.3	59.8	61.8	326.6	333.5	184	190.9	36.8	128.8	73.6	55.2	46
48	61.9	62.4	64.4	340.8	348.0	192	199.2	38.4	134.4	76.8	57.6	48
50	64.5	65.0	67.0	355.0	362.5	200	207.5	40.0	140.0	80.0	60.0	50
52	66.6	67.6	70.1	369.2	377.0	208	215.8	41.6	145.6	83.2	62.4	52
54	69.2	70.2	72.7	383.4	391.5	216	224.1	43.2	151.2	86.4	64.8	54
56	71.8	72.8	75.3	397.6	406.0	224	232.4	44.8	156.8	89.6	67.2	56
58	74.4	75.4	77.9	411.8	420.5	232	240.7	46.4	162.4	92.8	69.6	58
60	77.0	78.0	80.5	426.0	435.0	240	249.0	48.0	168.0	96.0	72.0	60
62	79.6	80.6	83.1	440.2	449.5	248	257.3	49.6	173.6	99.2	74.4	62
64	82.2	83.2	85.7	454.4	464.0	256	265.6	51.2	179.2	102.4	76.8	64
66	84.8	85.8	88.3	468.6	478.5	264	273.9	52.8	184.8	105.6	79.2	66
68	87.4	88.4	90.9	482.8	493.0	272	282.2	54.4	190.4	108.8	81.6	68
70	90.0	91.0	93.5	497.0	507.5	280	290.5	56.0	196.0	112.0	84.0	70
73	93.9	94.9	97.9	518.3	529.3	292	303.0	58.4	204.4	116.8	87.6	73
76	97.8	98.8	101.8	539.6	551.0	304	315.4	60.8	212.8	121.6	91.2	76
78	100.4	101.4	104.4	553.8	565.5	312	323.7	62.4	218.4	124.8	93.6	78
81	104.3	105.3	108.3	575.1	587.3	324	336.2	64.8	226.8	129.6	97.2	81
84	108.2	109.2	112.2	596.4	609.0	336	348.6	67.2	235.2	134.4	100.8	84
87	112.1	113.1	116.1	617.7	630.8	348	361.1	69.6	243.6	139.2	104.4	87
90	116.0	117.0	120.5	637.0	652.5	360	373.5	72.0	252.0	144.0	108.0	90
92	118.6	119.6	123.1	653.2	667.0	368	381.8	73.6	257.6	147.2	110.4	92
95	122.5	123.5	127.0	674.5	688.8	380	394.3	76.0	266.0	152.0	114.0	95
97	125.1	126.1	129.6	688.7	703.3	388	402.6	77.6	271.6	155.2	116.4	97
98	126.4	127.4	130.9	695.8	710.5	392	406.7	78.4	274.4	156.8	117.6	98
100	129.0	130.0	133.5	710.0	725.0	400	415.0	80.0	280.0	160.0	120.0	100
102	131.6	132.6	136.6	724.2	739.5	408	423.3	81.6	285.6	163.2	122.4	102
105	135.5	136.5	140.5	745.5	761.3	420	435.8	84.0	294.0	168.0	126.0	105
107	138.1	139.1	143.1	759.7	775.8	428	444.1	85.6	299.6	171.2	128.4	107
108	139.4	140.4	144.4	766.8	783.0	432	448.2	86.4	302.4	172.8	129.6	108
111	143.3	144.3	148.3	788.1	804.8	444	460.7	88.8	310.8	177.6	133.2	111
114	147.2	148.2	152.2	809.4	826.5	456	473.1	91.2	319.2	182.4	136.8	114
117	151.1	152.1	156.1	830.7	848.3	468	485.6	93.6	327.6	187.2	140.4	117
120	155.0	156.0	160.0	852.0	870.0	480	498.0	96.0	336.0	192.0	144.0	120
122	157.6	158.6	163.6	866.2	884.5	488	506.3	97.6	341.6	195.2	146.4	122
124	160.2	161.2	166.2	880.4	899.0	496	514.6	99.2	347.2	198.4	148.8	124
127	164.1	165.1	170.1	901.7	920.8	508	527.1	101.6	355.6	203.2	152.4	127
130	168.0	169.0	174.0	923.0	942.5	520	539.5	104.0	364.0	208.0	156.0	130
132	170.6	171.6	176.6	937.2	957.0	528	547.8	105.6	369.6	211.2	158.4	132
137	177.1	178.1	183.1	972.7	993.3	548	568.6	109.6	383.6	219.2	164.4	137
142	183.6	184.6	189.6	1008.2	1029.5	568	589.3	113.6	397.6	227.2	170.4	142
147	190.1	191.1	196.1	1043.7	1065.8	588	610.1	117.6	411.6	235.2	176.4	147
152	196.6	197.6	202.6	1079.2	1102.0	608	630.8	121.6	425.6	243.2	182.4	152

Steel Stud Link Chain & Fitting

Anchor Shackles (A/S)

$$D = 1.4 d + \text{Tolerance}$$

$$S = 2.1 d$$

$$L = 9d \begin{matrix} +0.15d \\ -0 \end{matrix}$$

$$T = 1.4 d$$

$$W = 5.05 d \begin{matrix} +0.15d \\ -0 \end{matrix}$$

$$R = 0.8 d$$

$$N = 3.0 d$$

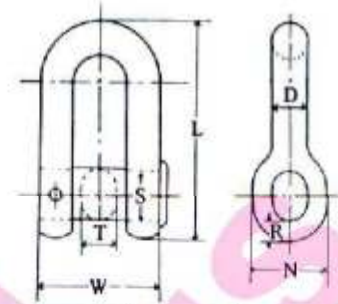

Nominal Dia.d	Diameter D			Length L		Width W		R	N	S	T
	Min.	Standard	Max.	Standard	Max.	Standard	Max.				
mm	mm	mm	mm	mm	mm	mm	mm	mm	mm	mm	mm
16	21.9	22.4	23.9	144.0	146.4	95	97.4	12.8	48.0	33.6	22.4
17.5	24.0	24.5	26.0	157.5	160.1	104	106.6	14.0	52.5	36.8	24.5
19	26.1	26.6	28.1	171.0	173.9	112	114.9	15.2	57.0	39.9	26.6
20.5	28.2	28.7	30.2	184.5	187.6	118	120.6	16.4	61.5	43.1	28.7
22	30.3	30.8	32.3	198.0	201.3	125	128.1	17.6	66.0	46.2	30.8
24	33.1	33.6	35.1	216	219.6	134	137.6	19.2	72	50.4	33.6
26	35.9	36.4	37.9	234	237.9	143	146.9	20.8	78	54.6	36.4
28	38.7	39.2	40.7	252	256.2	151	155.2	22.4	84	58.8	39.2
30	41.5	42.0	44.0	270	274.5	160	164.5	24.0	90	63.0	42.0
32	44.3	44.8	46.8	288	292.8	169	173.8	25.6	96	67.2	44.8
34	47.1	47.6	49.6	306	311.1	180	185.1	27.2	102	71.4	47.6
36	49.9	50.4	52.4	324	329.4	187	192.4	28.8	108	75.6	50.4
38	52.7	53.2	55.2	342	347.7	196	201.7	30.4	114	79.8	53.2
40	55.5	56.0	58.0	360	366.0	210	216.0	32.0	120	84.0	56.0
42	58.3	58.8	60.8	378	384.3	219	225.3	33.6	126	88.2	58.8
44	61.1	61.6	63.6	396	402.6	226	232.0	35.2	132	92.4	61.6
46	63.9	64.4	66.4	414	420.9	236	242.9	36.8	138	96.6	64.4
48	66.7	67.2	69.2	432	439.2	244	251.2	38.4	144	100.8	67.2
50	69.5	70.0	72.0	450	457.5	255	262.5	40.0	150	105.0	70.0
52	71.8	72.8	75.3	468	475.8	263	270.8	41.6	156	109.2	72.8
54	74.6	75.6	78.1	486	494.1	273	281.1	43.2	162	113.4	75.6
56	77.4	78.4	80.9	504	512.4	283	291.4	44.8	168	117.6	78.4
58	80.2	81.2	83.7	522	530.7	293	301.7	46.4	174	121.8	81.2
60	83.0	84.0	86.5	540	549.0	303	312.0	48.0	180	126.0	84.0
62	85.8	86.8	89.3	558	567.3	314	323.3	49.6	186	130.2	86.8
64	88.6	89.6	92.1	576	585.6	324	333.6	51.2	192	134.4	89.6
66	91.4	92.4	94.9	594	603.9	334	343.9	52.8	198	138.6	92.4
68	94.2	95.2	97.7	612	622.2	344	354.2	54.4	204	142.8	95.2
70	97.0	98.0	100.5	630	640.5	354	364.5	56.0	210	147.0	98.0
73	101.2	102.2	105.2	657	668.0	369	378.9	58.4	219	153.3	102.2
76	105.4	106.4	109.4	684	695.4	382	393.4	60.8	228	159.6	106.4
78	108.2	109.2	112.2	702	713.7	394	405.7	62.4	234	163.8	109.2
81	112.4	113.4	116.4	729	741.2	410	422.1	64.8	243	170.1	113.4
84	116.6	117.6	120.6	756	768.6	425	437.6	67.2	252	176.4	117.6
87	120.8	121.8	124.8	783	796.1	440	453.0	69.6	261	182.7	121.8
90	125.0	126.0	129.5	810	823.5	455	468.5	72.0	270	189.0	126.0
92	127.8	128.8	132.3	828	841.8	465	478.8	73.6	276	193.2	128.8
95	132.0	133.0	136.5	855	869.3	480	494.2	76.0	285	199.5	133.0
97	134.8	135.8	139.3	873	887.6	490	504.4	77.6	291	203.7	135.8
98	136.2	137.2	140.7	882	896.7	495	509.7	78.4	294	205.8	137.2
100	139.0	140.0	143.5	900	915.0	505	520.0	80.0	300	210.0	140.0
102	141.8	142.8	146.8	918	933.3	516	531.3	81.6	306	214.2	142.8
105	146.0	147.0	151.0	945	960.8	531	546.7	84.0	315	220.5	147.0
107	148.8	149.8	153.8	963	979.1	540	556.4	85.6	321	224.7	149.8
108	150.2	151.2	155.2	972	988.2	546	562.2	86.4	324	226.8	151.2
111	154.4	155.4	159.4	999	1015.7	561	577.6	88.8	333	233.1	155.4
114	158.6	159.6	163.6	1026	1043.1	576	593.1	91.2	342	239.4	159.6
117	162.8	163.8	167.8	1053	1070.6	591	608.5	93.6	351	245.7	163.8
120	167.0	168.0	172.0	1080	1098.0	606	624.0	96.0	360	252.0	168.0
122	169.8	170.8	175.8	1098	1116.3	617	635.3	97.6	366	256.2	170.8
124	172.6	173.6	178.6	1116	1134.6	627	645.6	99.2	372	260.4	173.6
127	176.8	177.8	182.8	1143	1162.1	642	660.4	101.6	381	266.7	177.8
130	181.0	182.0	187.0	1170	1189.5	657	676.0	104.0	390	273.0	182.0
132	183.8	184.8	189.8	1188	1207.8	667	686.8	105.6	396	277.2	184.8
137	190.8	191.8	196.8	1233	1253.6	692	712.5	109.6	411	287.7	191.8
142	197.8	198.8	203.8	1278	1299.3	718	739.3	113.6	426	298.2	198.8
147	204.8	205.8	210.8	1323	1345.1	743	765.0	117.6	441	308.7	205.8
152	211.8	212.8	217.8	1368	1390.8	768	790.8	121.6	456	319.2	212.8

Steel Stud Link Chain & Fitting

Swivel Pieces (S/P)

$D = SC\ 1.0d$ $SF\ 1.1d + \text{Tolerance}$ $W = 4.7d$
 $L = SC\ 8.9d$ $SF\ 8.8d \begin{smallmatrix} +0.15d \\ -0 \end{smallmatrix}$ $F = 1.125d$
 $E = SC\ 1.45d$ $SF\ 1.25d \begin{smallmatrix} +0.15d \\ -0 \end{smallmatrix}$ $G = 3.2b$

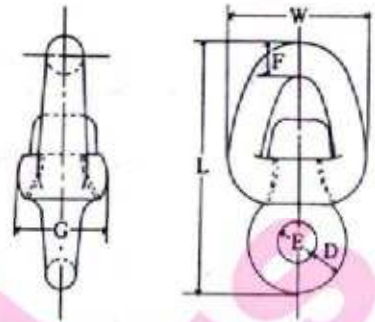

Nominal Dia. d	Cast Steel						W		F	G	Forged Steel			
	D			L			E	Standard			Max.	D	L	E
	Min.	Standard	Max.	Standard	Max.	mm								
16	15.5	16.0	17.5	142.4	144.8	23.2	75.2	77.6	18.0	51.2	17.6	140.8	20.0	
17.5	17.0	17.5	19.0	155.8	158.4	25.4	82.3	84.9	19.7	56.0	19.3	154.0	21.9	
19	18.5	19.0	20.5	169.1	172.0	27.6	89.3	92.2	21.4	60.8	20.9	167.2	23.8	
20.5	20.0	20.5	22.0	182.5	185.5	29.7	96.4	99.4	23.1	65.6	22.6	180.4	25.6	
22	21.5	22	23.5	195.8	199.1	31.9	103.4	106.7	24.8	70.4	24.2	193.6	27.5	
24	23.5	24	25.5	213.6	217.2	34.8	112.8	116.4	27.0	76.8	26.4	211.2	30.0	
26	25.5	26	27.5	231.4	235.3	37.7	122.2	126.1	29.3	83.2	28.6	228.8	32.5	
28	27.5	28	29.5	249.2	253.5	40.6	131.6	135.8	31.5	89.6	30.8	246.4	35.0	
30	29.5	30	32.0	267.0	271.5	43.5	141.0	145.5	33.8	96.0	33.0	264.0	37.5	
32	31.5	32	34.0	284.8	289.6	46.4	150.4	155.2	36.0	102.4	35.2	281.6	40.0	
34	33.5	34	36.0	302.6	307.7	49.3	159.8	164.9	38.3	108.8	37.4	299.2	42.5	
36	35.5	36	38.0	320.4	325.8	52.2	169.2	174.6	40.5	115.2	39.6	316.8	45.0	
38	37.5	38	40.0	338.2	343.9	55.1	178.6	184.3	42.8	121.6	41.8	334.4	47.5	
40	39.5	40	42.0	356.0	362.0	58.0	188.0	194.0	45.0	128.0	44.0	352.0	50.0	
42	41.5	42	44.0	373.8	380.1	60.9	197.4	203.7	47.3	134.4	46.2	369.6	52.5	
44	43.5	44	46.0	391.6	398.2	63.8	206.8	213.4	49.5	140.8	48.4	387.2	55.0	
46	45.5	46	48.0	409.4	416.3	66.7	216.2	223.1	51.8	147.2	50.6	404.8	57.5	
48	47.5	48	50.0	427.2	434.4	69.6	225.6	232.8	54.0	153.6	52.8	422.4	60.0	
50	49.5	50	52.0	445.0	452.5	72.5	235.0	242.5	56.3	160.0	55.0	440.0	62.5	
52	51.0	52	54.5	462.8	470.6	75.4	244.4	252.2	58.5	166.4	57.2	457.6	65.0	
54	53	54	56.5	480.6	488.7	78.3	253.8	261.9	60.8	172.8	59.4	475.2	67.5	
56	55	56	58.5	498.4	506.8	81.2	263.2	271.6	63.0	179.2	61.6	492.8	70.0	
58	57	58	60.5	516.2	524.9	84.1	272.6	281.3	65.3	185.6	63.8	510.4	72.5	
60	59	60	62.5	534.0	543.0	87.0	282.0	291.0	67.5	192.0	66.0	528.0	75.0	
62	61	62	64.5	551.8	561.1	89.9	291.4	300.7	69.8	198.4	68.2	545.6	77.5	
64	63	64	66.5	569.6	579.2	92.8	300.8	310.4	72.0	204.8	70.4	563.2	80.0	
66	65	66	68.5	587.4	597.3	95.7	310.2	320.1	74.3	211.2	72.6	580.8	82.5	
68	67	68	70.5	605.2	615.4	98.6	319.6	329.8	76.5	217.6	74.8	598.4	85.0	
70	69	70	72.5	623.0	633.5	101.5	329.0	339.5	78.8	224.0	77.0	616.0	87.5	
73	72	73	76.0	649.7	660.7	105.9	343.1	354.1	82.1	233.6	80.3	642.4	91.3	
76	75	76	79.0	676.4	687.8	110.2	357.2	368.6	85.5	243.2	83.6	668.8	95.0	
78	77	78	81.0	694.2	705.9	113.1	366.6	378.3	87.8	249.6	85.8	686.4	97.5	
81	80	81	84.0	720.9	733.1	117.5	380.7	392.9	91.1	259.2	89.1	721.8	101.3	
84	83	84	87.0	747.6	760.2	121.8	394.8	407.4	94.5	268.8	92.4	739.2	105.0	
87	86	87	90.0	774.3	787.4	126.2	408.9	422.0	97.9	278.4	95.7	765.6	108.8	
90	89	90	93.5	801.0	814.5	130.5	423.0	436.5	101.3	288.0	99.0	792.0	112.5	
92	91	92	95.5	818.8	832.6	133.4	432.4	446.2	103.5	294.4	101.2	809.6	115.0	
95	94	95	98.5	845.5	859.8	137.8	446.5	460.9	106.9	304.0	104.5	836.0	118.8	
97	96	97	100.5	863.3	877.9	140.7	455.9	470.5	109.1	310.4	106.7	853.6	121.3	
98	97	98	101.5	872.2	886.9	142.1	460.6	475.3	110.3	313.6	107.8	862.4	122.5	
100	99	100	103.5	890.0	905.0	145.0	470.0	485.0	112.5	320.0	110.0	880.0	125.0	
102	101	102	106.0	907.8	923.1	147.9	479.4	494.7	114.8	326.4	112.2	897.6	127.5	
105	104	105	109.0	934.5	950.3	152.3	493.5	509.3	118.1	336.0	115.5	924.0	131.3	
107	106	107	111.0	952.3	968.4	155.2	502.9	519.0	120.4	342.4	117.7	941.6	133.8	
108	107	108	112.0	961.2	977.4	156.6	507.6	523.8	121.5	345.6	118.8	950.4	135.0	
111	110	111	115.0	987.9	1004.6	161.0	521.7	538.4	124.9	355.2	122.1	976.8	138.8	
114	113	114	118.0	1014.6	1031.7	165.3	535.8	552.9	128.3	364.8	125.4	1003.2	142.5	
117	116	117	121.0	1041.3	1058.9	169.7	549.9	567.5	131.6	374.4	128.7	1029.6	146.3	
120	119	120	124.0	1068.0	1086.0	174.0	564.0	582.0	135.0	384.0	132.0	1056.0	150.0	
122	121	122	127.0	1085.8	1104.1	176.9	573.4	591.7	137.3	390.4	134.2	1073.6	152.5	
124	123	124	129.0	1103.6	1122.2	179.8	582.8	601.4	139.5	396.8	136.4	1091.2	155.0	
127	126	127	132.0	1130.3	1149.4	184.2	596.9	616.0	142.9	406.4	139.7	1117.6	158.8	
130	129	130	135.0	1157.0	1176.5	188.5	611.0	630.5	146.3	416.0	143.0	1144.0	162.5	
132	131	132	137.0	1174.8	1194.6	191.4	620.4	640.2	148.5	422.4	145.2	1161.6	165.0	
137	136	137	142.0	1219.3	1239.9	198.7	643.9	664.5	154.1	438.4	150.7	1205.6	171.3	
142	141	142	147.0	1263.8	1285.1	205.9	667.4	688.7	159.8	454.4	156.2	1249.6	177.5	
147	146	147	152.0	1308.3	1330.4	213.2	690.9	713.0	165.4	470.4	161.7	1293.6	183.8	
152	151	152	157.0	1352.8	1375.6	220.4	714.4	737.2	171.0	486.4	167.2	1337.6	190.0	

Steel Stud Link Chain & Fitting

Equipment Tables

Metric Units

Equipment Number		Equipment Letter					Stud Link Chain Cables for Bower Anchor				Stockless Bower Anchor	
Exceeding	Not Exceeding	NK	LR	AB	NV	BV	Total Length	Diameter			Number	Weight per Anchor
								Mild Steel (Grade 1)	Special Quality Steel (Grade 2)	Extra Special Quality Steel (Grade 3)		
							metres	mm	mm	mm		kg
50	70	A1	A	U1	--	--	220	14	12.5	--	2	180
70	90	A2	B	U2	--	--	220	16	14	--	2	240
90	110	A3	C	U3	--	--	247.5	17.5	16	--	2	300
110	130	A4	D	U4	--	--	247.5	19	17.5	--	2	360
130	150	A5	E	U5	--	--	275	20.5	17.5	--	2	420
150	175	B1	F	U6	--	--	275	22	19	--	2	480
175	205	B2	G	U7	--	--	302.5	24	20.5	--	2	570
205	240	B3	H	U8	--	--	302.5	26	22	--	3	660
240	280	B4	I	U9	--	--	330	28	24	--	3	780
280	320	B5	J	U10	--	--	357.5	30	26	--	3	900
320	360	C1	K	U11	--	--	357.5	32	28	--	3	1020
360	400	C2	L	U12	--	--	385	34	30	--	3	1140
400	450	C3	M	U13	--	--	385	36	32	--	3	1290
450	500	C4	N	U14	--	--	412.5	38	34	--	3	1440
500	550	C5	O	U15	--	--	412.5	40	34	--	3	1590
550	600	D1	P	U16	--	--	440	42	36	--	3	1740
600	660	D2	Q	U17	--	--	440	44	38	--	3	1920
660	720	D3	R	U18	--	--	440	46	40	--	3	2100
720	780	D4	S	U19	s	--	467.5	48	42	--	3	2280
780	840	D5	T	U20	t	--	467.5	50	44	--	3	2460
840	910	E1	U	U21	u	--	467.5	52	46	40	3	2640
910	980	E2	V	U22	v	--	495	54	48	42	3	2850
980	1060	E3	W	U23	w	--	495	56	50	44	3	3060
1060	1140	E4	X	U24	x	--	495	58	50	46	3	3300
1140	1220	E5	Y	U25	y	--	522.5	60	52	46	3	3540
1220	1300	F1	Z	U26	z	--	522.5	62	54	48	3	3780
1300	1390	F2	A1	U27	A	--	522.5	64	56	50	3	4050
1390	1480	F3	B1	U28	B	--	550	66	58	50	3	4320
1480	1570	F4	C1	U29	C	--	550	68	60	52	3	4590
1570	1670	F5	D1	U30	D	--	550	70	62	54	3	4890
1670	1790	G1	E1	U31	E	--	577.5	73	64	56	3	5250
1790	1930	G2	F1	U32	F	--	577.5	76	66	58	3	5610
1930	2080	G3	G1	U33	G	--	577.5	78	68	60	3	6000
2080	2230	G4	H1	U34	H	--	605	81	70	62	3	6450
2230	2380	G5	I1	U35	I	--	605	84	73	64	3	6900
2380	2530	H1	J1	U36	J	--	605	87	76	66	3	7350
2530	2700	H2	K1	U37	K	--	632.5	90	78	68	3	7800
2700	2870	H3	L1	U38	L	--	632.5	92	81	70	3	8300
2870	3040	H4	M1	U39	M	--	632.5	95	84	73	3	8700
3040	3210	H5	N1	U40	N	--	660	97	84	76	3	9300
3210	3400	J1	O1	U41	O	--	630	100	87	78	3	9900
3400	3600	J2	P1	U42	P	--	660	102	90	78	3	10500
3600	3800	J3	Q1	U43	Q	--	687.5	105	92	81	3	11100
3800	4000	J4	R1	U44	R	--	687.5	107	95	84	3	11700
4000	4200	J5	S1	U45	S	--	687.5	111	97	87	3	12300
4200	4400	K1	T1	U46	T	--	715	114	100	87	3	12900
4400	4600	K2	U1	U47	U	--	715	117	102	90	3	13500
4600	4800	K3	V1	U48	V	--	715	120	105	92	3	14100
4800	5000	K4	W1	U49	W	--	742.5	122	107	95	3	14700
5000	5200	K5	X1	U50	X	--	742.5	124	111	97	3	15400
5200	5500	L1	Y1	U51	Y	--	742.5	127	111	97	3	16100
5500	5800	L2	Z1	U52	Z	--	742.5	130	114	100	3	16900
5800	6100	L3	A*	U53	A*	--	742.5	132	117	102	3	17800
6100	6500	L4	B*	U54	B*	--	742.5	--	120	107	3	18800
6500	6900	L5	C*	U55	C*	--	770	--	124	111	3	20000
6900	7400	M1	D*	U56	D*	--	770	--	127	114	3	21500
7400	7900	M2	E*	U57	E*	--	770	--	132	117	3	23000
7900	8400	M3	F*	U58	F*	--	770	--	137	122	3	24500
8400	8900	M4	G*	U59	G*	--	770	--	142	127	3	26000
8900	9400	M5	H*	U60	H*	--	770	--	147	132	3	27500
9400	10000	N1	I*	U61	I*	--	770	--	152	132	3	29000
10000	10700			U62		--	770	--	--	137	3	31000
10700	11500			U63		--	770	--	--	142	3	33000
11500	12400			U64		--	770	--	--	147	3	35500
12400	13400			U65		--	770	--	--	152	3	38500
13400	14600			U66		--	770	--	--	157	3	42000
14600				U67		--	770	--	--	162	3	46000

Steel Stud Link Chain & Fitting

Testing Requirements

Lloyd's Register of Shipping

Metric Units

Inch/Pound Units

Chain Diameter	Grade				Minimum weight per length of 27.5m	
	U2		U3		With Dee Shackle	With Lugless Shackle
	Proof Load	Breaking Load	Proof Load	Breaking Load		
mm	kg	kg	kg	kg	kg	kg
12.5	6700	9400	9400	13500	107	105
14	8400	11800	11800	16800	130	127
16	10900	15300	15300	22000	160	157
17.5	13000	18300	18300	26100	190	186
19	15300	21500	21500	30700	220	216
20.5	17800	24900	24900	35600	252	248
22	20400	28600	28600	40900	290	286
24	24200	33900	33900	48500	350	345
26	28300	39700	39700	56700	410	405
28	32700	45800	45800	65500	480	475
30	37500	52400	52400	74900	550	545
32	42500	59400	59400	84900	620	615
34	47700	66800	66800	95500	700	690
36	53300	74600	74600	107000	785	775
38	59200	82800	82800	118000	875	860
40	65300	91400	91400	131000	965	950
42	71700	100000	100000	143000	1055	1040
44	78400	110000	110000	157000	1150	1130
46	85300	119000	119000	171000	1260	1240
48	92500	130000	130000	185000	1370	1345
50	100000	140000	140000	200000	1485	1455
52	108000	151000	151000	215000	1605	1575
54	116000	162000	162000	231000	1725	1690
56	124000	174000	174000	248000	1850	1810
58	132000	185000	185000	265000	1985	1945
60	141000	198000	198000	282000	2125	2075
62	150000	210000	210000	300000	2275	2220
64	159000	223000	223000	319000	2430	2370
66	169000	236000	236000	337000	2590	2525
68	178000	250000	250000	357000	2755	2685
70	188000	263000	263000	376000	2925	2850
73	203000	285000	285000	407000	3185	3130
76	219000	307000	307000	438000	3460	3360
78	230000	327000	327000	459000	3640	3535
81	246000	345000	345000	492000	3940	3820
84	263000	368000	368000	526000	4240	4105
87	280000	393000	393000	561000	4555	4405
90	298000	417000	417000	596000	4870	4705
92	310000	434000	434000	620000	5085	4905
95	329000	460000	460000	657000	5405	5210
97	341000	477000	477000	682000	5630	5425
100	360000	504000	504000	720000	5970	5745
102	373000	522000	522000	746000	6210	5970
105	393000	550000	550000	785000	6580	6320
107	406000	568000	568000	812000	6845	6575
111	433000	606000	606000	865000	7380	7080
114	453000	635000	635000	907000	7795	7475
117	474000	664000	664000	948000	8220	7870
120	495000	694000	694000	991000	8650	8270
122	510000	714000	714000	1019000	8960	8550
124	524000	734000	734000	1048000	9275	8835
127	546000	764000	764000	1092000	9740	9270
130	568000	795000	795000	1136000	10210	9710
132	583000	816000	816000	1165000	10540	10005
137	620000	868000	868000	1240000	11320	10750
142	658000	921000	921000	1316000	12110	11500
147	697000	975000	975000	1393000	12950	12300
152	736000	1030000	1030000	1471000	13890	13200

Chain Diameter	Grade				Minimum weight per length of 15 fathoms	
	U2		U3		With Dee Shackle	With Lugless Shackle
	Proof Load	Breaking Load	Proof Load	Breaking Load		
Inches	Tons	Tons	Tons	Tons	Cwt	Cwt
1/2	6.82	9.55	9.55	13.64	2-1/8	2-1/16
9/16	8.61	12.05	12.05	17.22	2-5/8	2-9/16
5/8	10.60	14.83	14.83	21.19	3-1/4	3-3/16
11/16	12.78	17.90	17.90	25.57	3-5/8	3-9/16
3/4	15.17	21.24	21.24	30.34	4-3/8	4-5/16
13/16	17.75	24.85	24.85	35.50	5-1/8	5-1/16
7/8	20.52	28.73	28.73	41.00	5-7/8	5-3/4
15/16	23.49	32.88	32.88	46.97	6-3/4	6-5/8
1	26.65	37.30	37.30	53.30	7-5/8	7-1/2
1-1/8	33.50	46.90	46.90	67.00	9-3/4	9-5/8
1-3/16	37.25	52.10	52.10	74.45	10-7/8	10-3/4
1-1/4	41.15	57.60	57.60	82.25	12	11-7/8
1-5/16	45.20	63.30	63.30	90.40	13-1/4	13-1/16
1-7/16	53.90	75.45	75.45	107.80	15-7/8	15-11/16
1-1/2	58.50	81.90	81.90	117.00	17-1/4	17
1-9/16	63.30	88.60	88.60	126.60	18-3/4	18-1/2
1-5/8	68.25	95.50	95.50	136.45	20	19-5/8
1-3/4	78.65	110.10	110.10	157.25	23-1/8	22-3/4
1-13/16	84.10	117.70	117.70	168.15	24-7/8	24-1/2
1-7/8	89.70	125.60	125.60	179.40	26-5/8	26-1/8
2	101.40	142.00	142.00	202.85	30	29-3/8
2-1/16	107.51	150.50	150.50	215.00	31-7/8	31-1/4
2-1/8	113.75	159.25	159.25	227.50	33-3/4	33
2-3/16	120.15	168.25	168.25	240.30	35-7/8	35-1/8
2-5/16	133.45	186.80	186.80	266.85	40	39-1/8
2-3/8	140.30	196.40	196.40	280.55	42-1/4	41-1/4
2-7/16	147.30	206.20	206.20	294.55	44-1/2	43-3/8
2-1/2	154.45	216.20	216.20	308.85	47	45-7/8
2-5/8	169.15	236.80	236.80	338.30	52	50-5/8
2-11/16	176.70	247.40	247.40	353.40	54-1/2	53-1/8
2-3/4	184.40	258.20	258.20	368.85	57-1/8	55-5/8
2-7/8	200.25	280.35	280.35	400.45	62-5/8	60-7/8
3	216.60	303.20	303.20	433.15	68-3/8	66-3/8
3-1/16	224.95	314.90	314.90	449.85	71-1/4	69-1/8
3-3/16	242.05	338.85	338.85	484.05	77-3/8	75
3-5/16	259.60	363.45	363.45	519.25	83-5/8	81
3-7/16	277.70	388.75	388.75	555.35	90-1/8	87-1/8
3-9/16	296.20	414.65	414.65	592.35	96-3/4	93-1/2
3-5/8	305.60	427.85	427.85	611.25	100	96-1/2
3-3/4	324.80	454.70	454.70	649.55	106-5/8	102-3/4
3-13/16	335.25	469.33	469.33	670.50	110-7/8	106-3/4
3-15/16	354.33	496.06	496.06	708.65	116-3/4	112-1/2
4	364.35	510.15	510.15	728.75	120-5/8	116
4-1/8	384.75	538.65	538.65	769.50	128-5/8	123-1/2
4-3/16	397.00	555.77	555.77	793.95	134-3/4	129-3/8
4-3/8	426.65	597.30	597.30	853.25	145-3/8	139-3/8
4-1/2	448.10	627.35	627.35	896.20	154-1/8	147-5/8
4-5/8	469.90	657.85	657.85	939.80	163	156
4-3/4	492.00	688.80	688.80	984.00	172	164-1/2
4-13/16	501.78	702.49	702.49	1000.36	176-5/8	168-5/8
4-7/8	515.73	722.03	722.03	1031.47	182-1/8	173-1/2
5	537.18	752.06	752.06	1074.36	191-5/8	182-1/2
5-1/8	558.87	782.42	782.42	1117.74	201-3/8	191-1/2
5-3/16	573.45	802.83	802.83	1146.91	207	196-1/2
5-3/8	610.33	854.46	854.46	1220.66	222-3/8	211-1/8
5-9/16	647.75	906.85	906.85	1295.51	237-3/8	225-1/2
5-3/4	685.66	959.93	959.93	1371.34	253-7/8	241
6	724.00	1013.61	1013.61	1448.01	274-1/8	260-1/2

Steel Stud Link Chain & Fitting

Testing Requirements.

American Bureau of Shipping

Metric Units

Inch-Pound Units

Chain Diameter	Length of Five Links	High Strength Grade 2		Extra-high Strength Grade 3		Min. Wt. per 27.5m	Chain Diameter	Length of Five Links	High Strength Grade 2		Extra-high Strength Grade 3		Min. Wt. per 15 Fathoms	
		Proof Load	Breaking Load	Proof Load	Breaking Load				Proof Load	Breaking Load	Proof Load	Breaking Load		
		kg	kg	kg	kg				kg	kg	kg	kg		
12.5	275	6700	9400	9400	13500	110	3/4	1	4 1/2	34000	47600	47600	68000	480
14	308	8400	11800	11800	16800	130	13/16	1	5 7/8	39800	55700	55700	79500	570
16	352	10900	15300	15300	22000	170	7/8	1	7 1/4	46000	64400	64400	91800	660
17.5	385	13000	18300	18300	26100	180	15/16	1	8 5/8	52600	73700	73700	105000	760
19	418	15300	21500	21500	30700	220	1	10	10	59700	83600	83600	119500	860
20.5	451	17800	24900	24900	35600	260	1 1/16	1	11 3/8	67200	94100	94100	135000	970
22	484	20400	28600	28600	40900	300	1 1/8	2	0 3/4	75000	105000	105000	150000	1080
24	528	24200	33900	33900	48500	340	1 3/16	2	2 1/8	83400	116500	116500	167000	1220
26	572	28300	39700	39700	56700	420	1 1/4	2	3 1/2	92200	129000	129000	184000	1350
28	616	32700	45800	45800	65500	480	1 5/16	2	4 7/8	101500	142000	142000	203000	1490
30	660	37500	52400	52400	74900	550	1 3/8	2	6 1/4	111000	155000	155000	222000	1630
32	704	42500	59400	59400	84900	610	1 7/16	2	7 5/8	120500	169000	169000	241000	1780
34	748	47700	66800	66800	95500	700	1 1/2	2	9	131000	183500	183500	262000	1940
36	792	53300	74600	74600	107000	790	1 9/16	2	10 3/8	142000	198500	198500	284000	2090
38	836	59200	82800	82800	118000	860	1 5/8	2	11 3/4	153000	214000	214000	306000	2240
40	880	65300	91400	91400	131000	970	1 11/16	3	1 1/8	166500	229000	229000	327000	2410
42	924	71700	100000	100000	143000	1070	1 3/4	3	2 1/2	176000	247000	247000	352000	2590
44	968	78400	110000	110000	157000	1170	1 13/16	3	3 7/8	188500	264000	264000	377000	2790
46	1012	85300	119000	119000	171000	1270	1 7/8	3	5 1/4	201000	281000	281000	402000	2980
48	1056	92600	130000	130000	185000	1380	1 15/16	3	6 5/8	214000	299000	299000	427000	3180
50	1100	100000	140000	140000	200000	1480	2	3	8	227000	318000	318000	454000	3360
52	1144	108000	151000	151000	215000	1600	2 1/16	3	9 3/8	241000	337000	337000	482000	3570
54	1188	116000	162000	162000	231000	1720	2 1/8	3	10 3/4	255000	357000	357000	510000	3790
56	1232	124000	174000	174000	248000	1850	2 3/16	4	0 1/8	269000	377000	377000	538000	4020
58	1276	132000	185000	185000	265000	1990	2 1/4	4	1 1/2	284000	396000	396000	570000	4250
60	1320	141000	198000	198000	282000	2120	2 5/16	4	2 7/8	299000	419000	419000	598000	4490
62	1364	150000	210000	210000	300000	2250	2 3/8	4	4 1/4	314000	440000	440000	628000	4730
64	1408	159000	223000	223000	319000	2440	2 7/16	4	5 5/8	330000	462000	462000	660000	4960
66	1452	169000	236000	236000	337000	2590	2 1/2	4	7	346000	484000	484000	692000	5270
68	1496	178000	250000	250000	357000	2750	2 9/16	4	8 3/8	363000	507000	507000	726000	5540
70	1540	188000	263000	263000	376000	2910	2 5/8	4	9 3/4	379000	530000	530000	758000	5820
73	1606	203000	285000	285000	407000	3180	2 11/16	4	11 1/8	396000	554000	554000	820000	6110
76	1672	219000	307000	307000	438000	3470	2 3/4	5	0 1/2	413000	578000	578000	826000	6410
78	1716	230000	322000	322000	459000	3650	2 13/16	5	1 7/8	431000	603000	603000	861000	6710
81	1782	246000	345000	345000	492000	3930	2 7/8	5	3 1/4	449000	628000	628000	897000	7020
84	1848	263000	368000	368000	526000	4250	2 15/16	5	4 5/8	467000	654000	654000	934000	7330
87	1914	280000	393000	393000	561000	4560	3	5	6	485000	679000	679000	970000	7650
90	1980	298000	417000	417000	596000	4860	3 1/16	5	7 3/8	504000	705000	705000	1008000	7980
92	2024	310000	434000	434000	620000	5100	3 1/8	5	8 3/4	523000	732000	732000	1046000	8320
95	2090	329000	460000	460000	657000	5400	3 3/16	5	10 1/8	542000	759000	759000	1084000	8660
97	2134	341000	477000	477000	682000	5670	3 1/4	5	11 1/2	562000	787000	787000	1124000	9010
98	2156	347000	486000	486000	695000	5750	3 5/16	6	0 7/8	582000	814000	814000	1163000	9360
100	2200	360000	504000	504000	720000	6010	3 3/8	6	2 1/4	602000	843000	843000	1204000	9760
102	2244	373000	522000	522000	746000	6250	3 7/16	6	3 5/8	622000	871000	871000	1244000	10100
105	2310	393000	550000	550000	785000	6600	3 1/2	6	5	643000	900000	900000	1285000	10500
107	2354	406000	568000	568000	812000	6820	3 9/16	6	6 3/8	664000	929000	929000	1327000	10900
108	2376	412000	577000	577000	825000	6950	3 5/8	6	7 3/4	685000	958000	958000	1369000	11300
111	2442	433000	606000	606000	865000	7290	3 3/4	6	10 1/2	728000	1019000	1019000	1455000	12000
114	2508	453000	635000	635000	907000	7640	3 7/8	7	1 1/4	772000	1080000	1080000	1543000	12900
117	2574	474000	664000	664000	948000	7980	3 15/16	7	2 5/8	794000	1111000	1111000	1587000	13300
120	2640	495000	694000	694000	991000	8310	4	7	4	816000	1143000	1143000	1632000	13700
122	2684	510000	714000	714000	1019000	8620	4 1/8	7	6 3/4	862000	1207000	1207000	1724000	14600
124	2728	524000	734000	734000	1048000	8920	4 1/4	7	9 1/2	908000	1272000	1272000	1817000	15400
127	2794	546000	764000	764000	1092000	9380	4 3/8	8	0 1/4	956000	1338000	1338000	1911000	16200
130	2860	568000	795000	795000	1136000	9840	4 1/2	8	3	1004000	1405000	1405000	2008000	17100
132	2904	583000	816000	816000	1165000	10140	4 5/8	8	5 3/4	1053000	1474000	1474000	2105000	18000
137	3014	620000	868000	868000	1240000	10910	4 3/4	8	8 1/2	1102000	1543000	1543000	2204000	18900
142	3124	658000	921000	921000	1316000	11670	4 7/8	8	11 1/4	1153000	1613000	1613000	2305000	19900
147	3234	697000	975000	975000	1393000	12440	5	9	2	1203000	1685000	1685000	2407000	20900
152	3344	736000	1030000	1030000	1471000	13200	5 1/8	9	4 3/4	1255000	1757000	1757000	2509000	22000
157	3454	775000	1085000	1085000	1550000	14000	5 3/8	9	10 1/4	1359000	1903000	1903000	2718000	24000
162	3564	816000	1142000	1142000	1631000	14700	5 5/8	10	3 3/4	1466000	2052000	2052000	2932000	26100
							5 3/4	10	6 1/2	1520000	2128000	2128000	3039000	27000
							6	11	0	1629000	2280000	2280000	3257000	28100
							6 1/8	11	2 3/4	1684000	2357000	2357000	3367000	30200
							6 3/8	11	8 1/4	1795000	2512000	2512000	3589000	32400